



LISTING INFORMATION OF CCI Manufacturing Inc. - HiBAR

SPEC ID: 30390

CCI Manufacturing Inc.
16355-130 Ave

Edmonton, AB T5V 1K5
Canada

This report is for the exclusive use of Intertek's Client and is provided pursuant to the agreement between Intertek and its Client. Intertek's responsibility and liability are limited to the terms and conditions of the agreement. Intertek assumes no liability to any party, other than to the Client in accordance with the agreement, for any loss, expense or damage occasioned by the use of this report. Only the Client is authorized to permit copying or distribution of this report and then only in its entirety. Any use of the Intertek name or one of its marks for the sale or advertisement of the tested material, product or service must first be approved in writing by Intertek. The observations and test results in this report are relevant only to the sample tested. This report by itself does not imply that the material, product, or service is or has ever been under an Intertek certification program.

DESCRIPTION

HIBAR™ is a spray applied semi cementitious mineral fiber insulation generally used for fire rating structural steel. HIBAR™ can be applied over rigid structural substrates, and exterior or partition walls. It provides acoustical treatment for ceilings and walls in noisy production areas or rooms such as gymnasiums or swimming pools where both sound absorption and aesthetic enhancement are desired. Condensation control is also provided on exposed structural components that are in contact with cold exterior surfaces.

EVALUATED TO THE FOLLOWING

- | CAN/ULC S124, *Evaluation of Protective Coverings for Foamed Plastic.*
- | CAN/ULC S101, *Fire Endurance Tests of Building Construction and Materials*

RATINGS

Standard	Minimum Applied Thickness	Minimum Applied Density	Classification / Rating
CAN/ULC S124-06	Sprayed wet 1-1/2" (1-1/4" dry)	169 kg/m ³	A
CAN/ULC S101*	As per Design Listings CCI-MFF 60-01, CCI-MFF 120-01, and CCI-MFF 180-01 uploaded in the Design section of this specification.		

<u>Attribute</u>	<u>Value</u>
Criteria	CAN / ULC S101 (2007)
Criteria	ULC S124 (2006)
CSI Code	07 81 33 Mineral-Fiber Fireproofing
Intertek Services	Certification
Listed or Inspected	LISTED
Listing Section	OTHER PRODUCTS
Report Number	101181672COQ-002, 101312599COQ-003, 08CA08497, 84T487, 85T246, 86T422, 85T245
Spec ID	30390

DRAWING INDEX

2014-02-04 CCI Manufacturing, Inc - CCI-MFF 120-01 DL Wall.pdf

2014-02-04 CCI Manufacturing, Inc - CCI-MFF 60-01 DL Roof Assembly.pdf

2014-02-04 CCI Manufacturing, Inc - CCI-MMF 180-01 DL Steel Building Column.pdf

2014-02-04 CCI Manufacturing, Inc - CCI-MFF 120-01 DL Wall.pdf

07 81 33 Mineral-Fiber Fireproofing

Page 1 of 2

Design Number : CCI/MFF 120-01
CCI MANUFACTURING INC.
 CAN / ULC S101
 Fire Rating Only - Load Rating Not Within The Scope Of This Listing
(Exposed to Fire on Interior Side Only)
 Assembly Rating – up to 2 hour

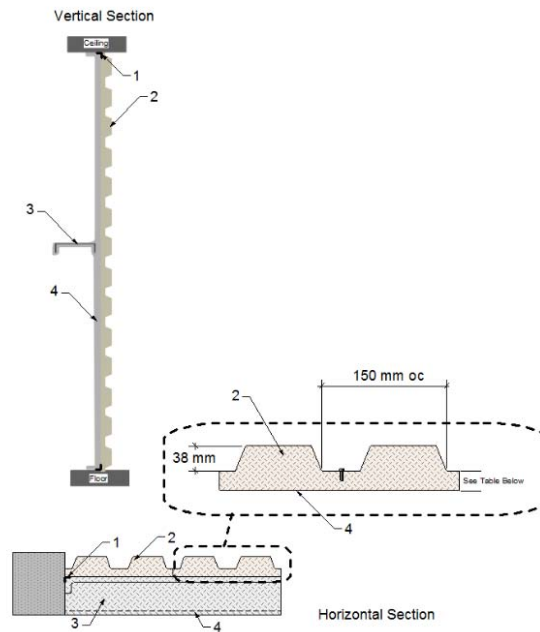

1. **SUPPORT ANGLES:** Cold rolled steel angles 75 mm x 75 mm x 6 mm across the top and bottom of the wall, and a 55 mm x 55 mm x 6 mm thick angle at each side. Angles attached to masonry with 60 mm long 9.5 mm dia. steel bolts, or steel or cast iron expansion shells spaced 600m on center (oc).

2. **WALL AND PARTITION FACING UNITS:** 0.67 mm thick galvanized sheet steel facing units with 38 mm deep flutes

150 mm oc. Panels fastened with No. 14 - 19 mm self tapping screws.

3. **STEEL CHANEL:** (Optional) cold rolled channel c200x17, where required, welded to 100 mm x 100 mm 6 mm angles. Angles attached to masonry with two 60 mm long, 9.5 mm dia steel bolts, or studs and steel or cast iron expansion shells.

4. **SPRAY FIBRE:** Designated as HiBAR™ applied to interior face of

Date: February 2, 2014
 Project No: G101181672



2014-02-04 CCI Manufacturing, Inc - CCI-MFF 120-01 DL Wall.pdf (page 2 of 2)

07 81 33 Mineral-Fiber Fireproofing

Page 2 of 2

wall to minimum thickness and densities indicated in the below table. Steel surface must be clean and free of dirt, loose scale and oily deposits.

Assembly Rating (h)	Hibar Minimum Thickness (mm)		Minimum Density (kg/m ³)	
	Applied as Facing	Applied over Channel	Average	Individual
1	38	48	245	205
2	86	61	179	171

Date: February 2, 2014
Project No: G101181672



2014-02-04 CCI Manufacturing, Inc - CCI-MFF 60-01 DL Roof Assembly.pdf

07 81 33 Mineral-Fiber Fireproofing

Page 1 of 2

Design Number : CCI/MFF 60-01

CCI MANUFACTURING INC.

CAN / ULC S101

Restrained Assembly Rating – up to 1 hour

Unrestrained Assembly Rating – up to 1/2 hour (see Steel Roof Deck, Item #5)

Unrestrained Beam Rating – up to 1 hour

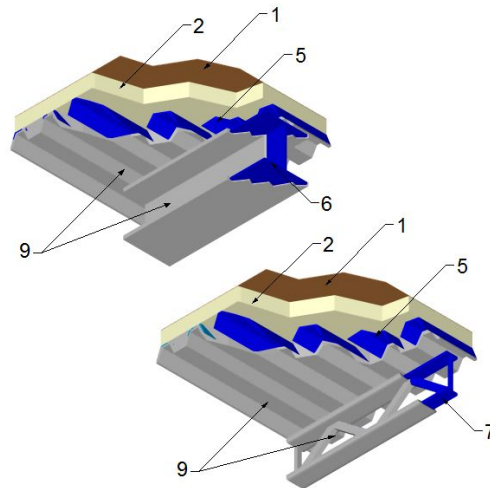

1. ROOF COVERING: Class A, B, or C built-up roof covering consisting only of felt and asphalt in alternate layers, installed in accordance with the manufacturer's installation instructions.
2. RIGID ROOF INSULATION: 915 mm x 1220 mm Glass Fibre board panels with a minimum thickness of 70 mm and maximum thickness 100 mm. Applied with adhesive to vapour barrier or steel deck. End joints shall be staggered 600 mm on center (oc) in adjacent rows. When applied in more than one layer (100 mm maximum total thickness) all joints shall be staggered 300 mm from those of the previous layer, and subsequent layers shall be applied with hot mopping asphalt applied at the rate of 14.6 kg/m³.
3. SHEATHING MATERIAL (optional): Applied to steel deck with adhesive, adjacent sheets overlapped an average of 50 mm.
4. ADHESIVE: Applied to steel deck (and vapour barrier if used) at the rate specified in the manufacturer's listing.
5. STEEL ROOF DECK: Fluted galvanized steel deck 38 mm deep and 910 mm wide, with a minimum 0.8 mm thickness. Flutes approximately 145 mm oc, crests approximately 80 mm wide, and valleys approximately 40 mm wide. Attached to joist and beam with 20 mm dia welds spaced 300 mm oc and at both sides of deck joints. Adjacent units crimped along

Date Revised: February 2, 2014
Project No: 101181672



2014-02-04 CCI Manufacturing, Inc - CCI-MFF 60-01 DL Roof Assembly.pdf (page 2 of 2)

07 81 33 Mineral-Fiber Fireproofing

Page 2 of 2

- joints at 400 mm oc. When the maximum clear span of the steel roof deck is less than or equal to the tested span of 1700 mm the unrestrained assembly rating may be increase to 1h.
6. BEAM: W150 – 18 minimum size.
 7. JOIST: 250 mm deep, 20 kg/m minimum size open web steel joist, designed in accordance with the relevant provisions of Chapter 4 of the Supplement to the National Building Code of Canada. Spaced 1700 mm oc.
 8. BRIDGING – Designed in accordance with the relevant provisions of chapter 4 of the Supplement to the National Building Code of Canada.
 9. SPRAYED FIBER: HIBAR™ fiber for application with or with out adhesive to steel surfaces in thicknesses indicated below. Fiber to have a minimum average dry density of 153 kg/m³ with no minimum individual value less than 139 kg/m³. Steel surface must be clean and free of dirt, loose scale and oily deposits.

Assembly Rating (h)	Hibar Minimum Thickness (mm)		Minimum Density (kg/m ³)	
	Applied as Facing	Applied over Channel	Average	Individual
1	38	48	245	205
2	86	61	179	171

Date Revised: February 2, 2014
Project No: 101181672



2014-02-04 CCI Manufacturing, Inc - CCI-MMF 180-01 DL Steel Building Column.pdf

07 81 33 Mineral-Fiber Fireproofing

Page 1 of 1

Design Number : CCI/MFF 180-01
CCI MANUFACTURING INC.
 CAN / ULC S101

Fire Rating Only - Load Rating Not Within The Scope Of This Listing
 Assembly Rating – up to 3 hour

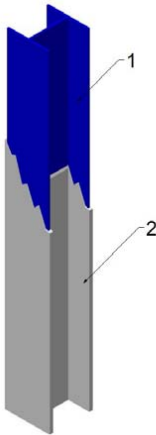

1. Steel Building Column as required from table below.
2. SPRAY FIBRE: Designated as HiBAR™ applied in one coat to the minimum thickness as required in the below table. Fiber to have a minimum average dry density of 187 kg/m³. Minimum individual dry density values shall not be less than 174 kg/m³. Steel

surfaces must be clean and free of dirt, loose scale, and oil.

Minimum Steel Size	Min Thickness of Spray Applied Fire Resistive Material Required for Indicated Rating (mm)			
	1h	1.5h	2h	3h
W200x42	22	44	58	-
W250x73	18	33	48	-
W310x143	13	25	35	-
W360x347	10	11	19	30

Date Revised: February 2, 2014
 Project No: G101181672



Design Number : CCI/MFF 120-02
CCI MANUFACTURING INC.
ASTM E119
CAN/ULC S101
Restrained Assembly Rating – up to 2 h
Unrestrained Assembly Rating – up to 1 h
Unrestrained Beam Rating – up to 1 h

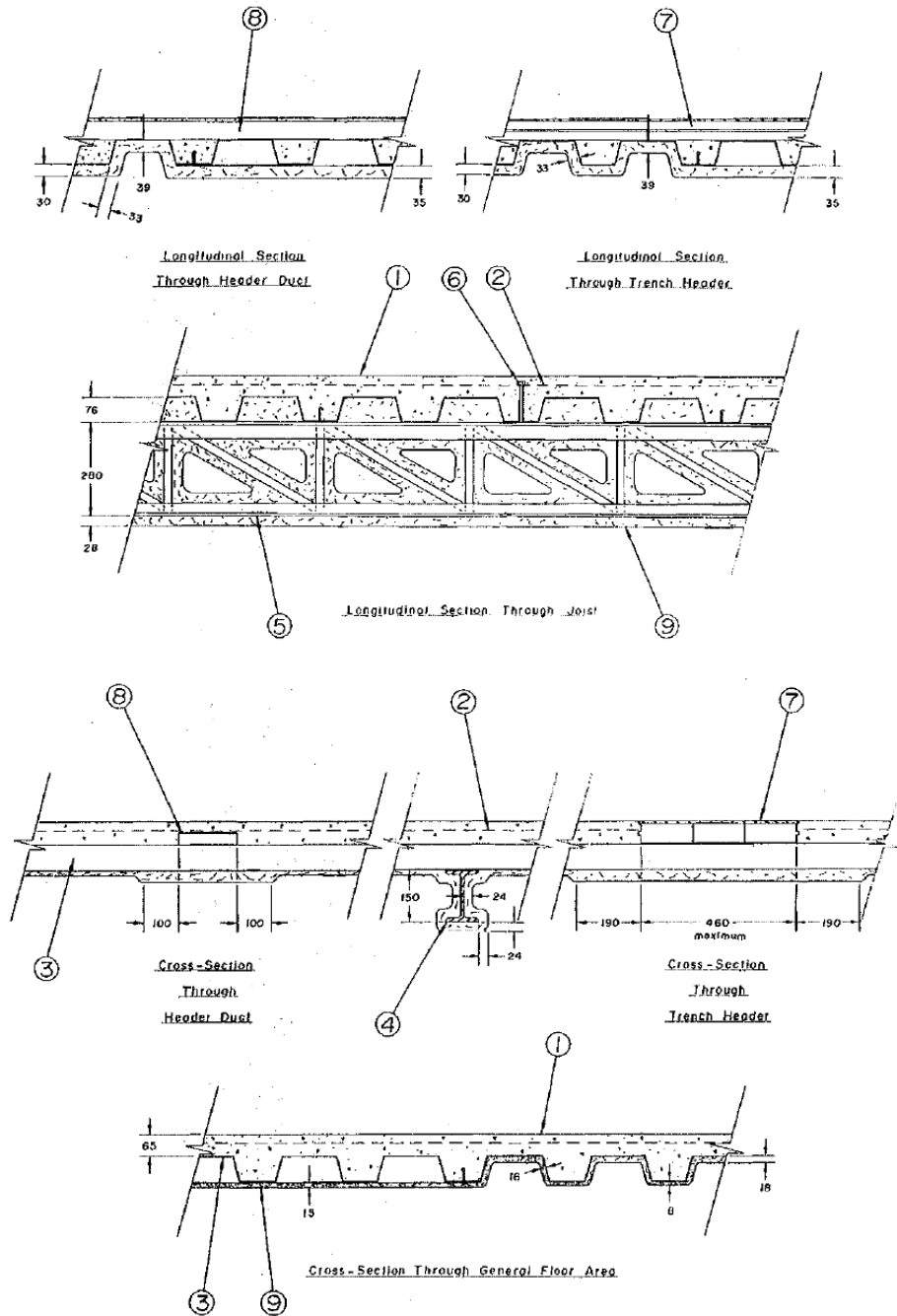

1. SAND AND GRAVEL CONCRETE: 20 MPa nominal compressive strength, with a 2440 kg/m³ density.
2. WIRE FABRIC: 152 mm x 152 mm MW 9.9/M 9.1 wire mesh.
3. STEEL FLOORING UNITS: Composite or non-composite with 0.091 mm thick fluted sections, or alternating one 900 mm wide 0.91 mm thick fluted section to a max of one 900 mm wide 0.091/0.091 mm cellular section. Units are to be welded to supports with 19 mm dia plug welds, spaced at every trough. Adjacent units crimped along joints at 460 mm on center. Thickness of fluted sections may be reduced to 0.76 mm for ratings not exceeding 1 h.
4. BEAM: W150 x 18, Min Size.
5. OPEN WEB STEEL JOIST: 280 mm deep, 20 kg/m³ min size, designed in accordance with the relevant provisions of the National Building Code of Canada. For composite design use Item 6.
6. SHEAR CONNECTORS (Optional) Headed type, welded to top flange of joist or beam through the decks.
7. TRENCH-HEADER: Steel housing with a max width of 460 mm.
8. HEADER DUCT – 170 mm wide by 35mm deep with 100 mm access holes.
9. SPRAYED FIBER: HiBAR™ applied on steel surfaces in thicknesses indicated in above drawings. Fiber must have a min average dry density of 149 kg/m³ with no min individual value less than 140 kg/m³. Steel Surface must be clean and free of dirt, loose scale and oily deposits.